

ARTICLE 7
TND, TRADITIONAL NEIGHBORHOOD DEVELOPMENT DISTRICT

- Sec. 7.1. Purpose and Description.
- Sec. 7.2. Character.
- Sec. 7.3. Permitted and Conditional Uses.
- Sec. 7.4. Dimensional Requirements.
- Sec. 7.5. Additional Development Requirements.

Sec. 7.1. Purpose and Description.

This zoning district is intended to provide for neighborhoods that are designed according to the principles of “new urbanism” with a grid or modified-grid street network, pedestrian scale and orientation, shallow front yards, relatively narrow local streets planted with shade trees and provided with wide sidewalks, and with automobile garages accessed via alleys or located to the rear of residential lots. TND districts are further distinguished from conventional suburban subdivision developments in their provision of public greens or common areas, when new neighborhoods are created.

Sec. 7.2. Character.

Development within this district consists mostly of residential neighborhoods in a rectangular or square block, lot, and street pattern.

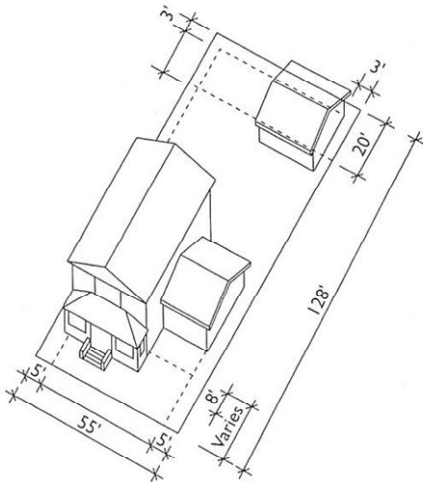

Source: Kindell, Peter J., “Building Types,” p. 189 in *Planning and Urban Design Standards*. Hoboken, NJ: John Wiley & Sons, 2006)

Consistent: Dwelling contains front porch and is located close to street. Minimal side yard setbacks. Garage is detached and located at rear of lot. Lot dimensions are 45'-60' in width and approximately 100'-130' in depth (6,700 to 7,500 square feet of lot area).



Source: Hill, John, W. Design Characteristics of Maryland's Traditional Communities, Figure 4, p. 5.1-2 in *Time Saver Standards for Urban Design* (New York: McGraw-Hill, 2003)

Consistent: TND Street View – the original settlement pattern sets the character and establishes building themes that should be continued, including location of buildings close to the street and porches on the front of dwellings.

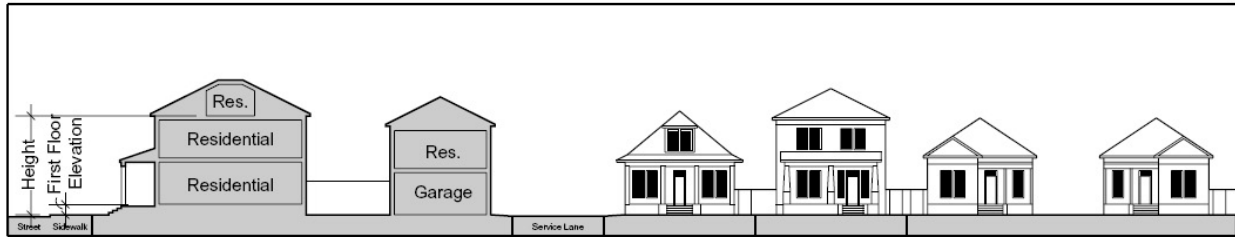

Source: Nashville, Tennessee, Metro Planning Department. 31st Avenue/Long Boulevard Urban Design Overlay. Adopted 3/16/04. Attachment to Ordinance No. BL 2004-151.

Sec. 7.3. Permitted and Conditional Uses.

Permitted and conditional uses shall be as provided in Table 7.1, “Permitted and Special Uses in Traditional Neighborhood Development Districts.” Land use in this district consists predominantly of detached, single-family dwellings, stick-built, on their own lots. Duplexes and townhouses are conditional uses. Other uses that contribute to or serve the neighborhood, such as recreational, educational, and religious facilities, are permitted or conditional uses.

Sec. 7.4. Dimensional Requirements.

Dimensional requirements shall be as provided in Table 7.2, “Dimensional Requirements in Traditional Neighborhood Development Districts.” Densities permitted are up to 6.5 dwelling units per acre. Minimal building setbacks from city streets are required.

Sec. 7.5. Additional Development Requirements.

- (a) Maximum Block Width and Block Length. When a new subdivision is created within this district, the lots shall be designed in a grid-like pattern of blocks and interconnecting streets, where no new block created shall have a length or width exceeding 800 feet in length without an alley or intervening (mid-block) pedestrian footpaths.



Source: Arendt, Randall. 1999. *Crossroads, Hamlet, Village, Town: Design Characteristics of Traditional Neighborhoods, Old and New.* PAS Report No. 487/488, Figure 90, p. 58. Chicago: American Planning Association.

- (b) Front Porches. Any new, detached dwelling shall be encouraged to have a front porch no less than twenty feet in width as measured along the street frontage and no less than six feet in depth measured from the front property line to the interior of the lot. If provided, front porches may extend into the required front building setback by six feet.

- (c) On-site Parking. Off-street parking between the front façade of the principal dwelling and the city street shall be prohibited. Any on-site parking if unenclosed shall be located in the rear yard. If on-site parking is provided within a garage, the garage shall be located in the rear yard of the lot or in the side yard with the entrance facing (parallel to) the rear lot line. If off-street parking, whether within a garage, carport, or in the open air, must be directly accessed from the street on which the dwelling fronts, the garage, carport, or parking area shall be recessed back at least five feet behind the front wall of the dwelling so that it is subordinate rather than dominant when viewed from the city street on which the dwelling fronts.

- (d) Pedestrian Access to Street Right-of-Way. Any new, detached dwelling shall provide pedestrian access (an improved walkway at least four feet in width that connects the dwelling to the right-of-way of the street on which it fronts; the pedestrian walkway shall connect to the street sidewalk system, where it exists. Garages for the parking of automobiles shall be setback at least twenty feet from the front property line.

Table 7.1
Permitted and Conditional Uses in
Traditional Neighborhood Development Districts
(P = Permitted Use C = Conditional Use X = Prohibited)

Use	TND
Accessory apartment, attached	C
Accessory apartment, detached, above a garage in rear yard	P
Accessory building, structure, or use	P
Church, temple, synagogue, or place of worship, including cemetery as accessory use	C
Adaptive reuse of a detached single-family dwelling for a club or lodge, nonprofit, sponsored by a civic or similar organization	P
Club or lodge, nonprofit, sponsored by a civic or similar organization, other than adaptive reuse of a detached single-family dwelling	P
Community recreation	P
Conservation areas and passive recreational facilities	P
Dwelling, single-family detached, fee-simple	P
Dwellings, single-family detached, condominium	C
Dwelling, townhouse (single-family attached, fee-simple)	C
Dwelling, two-family (duplex)	C
Dwelling, multi-family (apartment, attached residential condominium)	X
Dwelling, located within a building containing a nonresidential principal use	C
Garden, non-commercial, accessory to single-family detached dwelling	P
Greenhouse, non-commercial, accessory to single-family detached dwelling	C
Guest house (accessory building/use)	P
Home occupation, including family day care home	P
Institutional residential living and care facility, serving no more than 17 persons	C
Live/work unit	C
Mixed use development, within a detached single-family dwelling (adaptive reuse)	C
Modular home (single-family, detached)	P
Office, within a detached single-family dwelling (adaptive reuse)	P
Office, other than adaptive reuse of a detached single-family dwelling	C
Personal service establishment, within a detached single-family dwelling only (adaptive reuse)	C
Retail trade establishment, enclosed within a detached single-family dwelling only (adaptive reuse)	C
Public or semi-public use	P
School, private, elementary, middle, or high	C
School, public	P
School, special	C
Temporary use	P
Zero lot line housing	C

**Table 7.2
 Dimensional Requirements for Traditional Neighborhood Development Districts**

Requirement (measurement unit)	TND
Maximum height (feet)	30
Maximum height (number of stories)	2
Maximum density (units per acre)	6.5
Minimum lot size for detached single-family dwelling (square feet)	6,700
Minimum lot size for two-family dwelling (square feet)	13,400
Minimum lot size for other uses (square feet)	5,000
Minimum lot width (feet)	45
Minimum lot depth (feet)	80
Minimum heated floor area per dwelling unit (square feet)	1,200
Minimum front yard setback from lot line (feet)	15
Minimum front yard setback from lot line, garage for parking of automobiles (feet)	20
Minimum side setback, interior lot line or corner lot, all principal buildings (feet)	5
Minimum rear setback, all principal buildings (feet)	25
Rear setback for an accessory building when abutting an alley	None
Minimum landscape strip required along right-of-ways for any nonresidential use if permitted (width in feet)	15
Maximum coverage of principal and accessory buildings (percent of lot)	50
Maximum floor-area ratio, non-residential use, mixed use, or live/work unit	0.6
Minimum landscaped open space, all principal uses except detached, single-family residential lots, townhouses, and two-family dwellings (percent)	20